



Mega Clamps 63-125mm

Product Code: Straight 53MB0101, Universal 53MB0102

Operating Instructions

REVISION: 01



Helping you make the right connections.

© **Copyright Caldervale Technology Ltd.**

The copyright for this product and instruction manual is held by Caldervale Technology Ltd. Any technical specifications, or illustrations part of this manual cannot be reproduced, used illicitly or distributed in any form for competitive purposes.

Contents	Page
01. Introduction	02
02. Safety Instructions	03
03. Operation: Megaclamp Straight	04
04. Operation: Megaclamp Universal	06
05. Specifications: Megaclamp Straight	08
06. Specifications: Megaclamp Universal	09
07. Parts Diagram	10
08. Warranty Information	11
09. Service and Repair	13
10. Decommissioning and Disposal	13
Certificate of Conformity	14

01. Introduction

General Description

Mega Clamps are designed for restraining the movement of medium diameter pipes and couplers for service installations. They fit pipe sizes from 63mm through to 125mm.

The clamps have rotating plates with cut outs to suit a range of pipe sizes, allowing quick and easy changing of size for couplers and reducers.

The tool is designed to clamp and hold pipe to provide stability and prevent movement primarily for electrofusion purposes with any polyethylene pipe material (new, weathered or previously installed) in accordance with Gas Industry Standards GIS/PL2-5 Part 5 Electrofusion Ancillary Tools.

This product (Megaclamp) has been manufactured, inspected and tested in accordance with the ISO9001 quality control systems and procedures in place at Caldervale Technology Ltd, Dewsbury.

Before Using

It is important to ensure all component parts are present and in serviceable condition.

The condition of the tool should be inspected thoroughly prior to use.



Important!

This tool should be used in accordance with the pipe manufacturers' recommendations and in line with local codes of practice.

This manual outlines the operation of the pipe clamping tool for PE pipe and forms a part of the product to which it relates. It should be kept for the life of the product. Any amendments issued by Caldervale Technology Ltd should be incorporated in the text. The manual should be passed to any subsequent holder or user of this product.

02. Safety Instructions

1. Read and understand the whole booklet before using the tool.
2. It is imperative that all possible precautions are made to avoid unexpected movement of the tool and pipe during use.
3. Never attempt to operate on pipes that are not within the specified dimensions.
4. Operatives should wear eye protection, gloves, safety headwear & footwear when using the equipment.

03. Operation: Megaclamp Straight

Instructions for Use

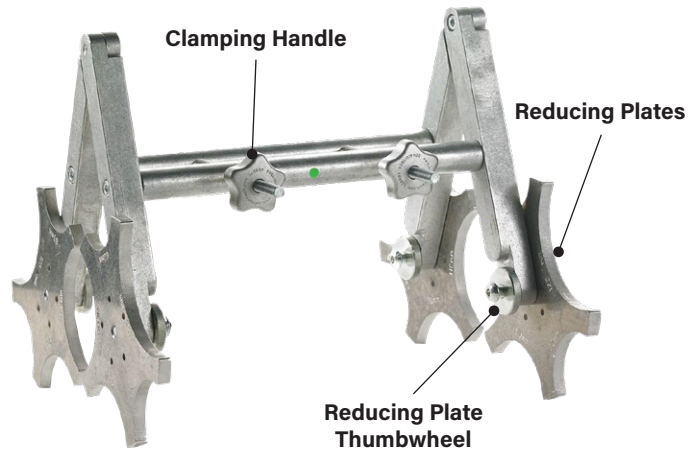

1. Check the pipe size and select the correct side of the reducing plates.
2. If a different size is required, turn the reducing plate thumbwheel anticlockwise fully. Pulling the plate away from the locating pin will allow the plate to rotate. Rotate the plate until the desired size is between the jaws. Note; if using a reducing coupler different sides of the plates can be used at either side of the clamp.
3. The reducing plate should be pushed onto the locating pin to prevent unwanted rotation. Then turn the reducing plate thumbwheel clockwise to lock in place.
4. Repeat steps 2 and 3 for the remaining legs of the tool.
5. Turn clamping handles anticlockwise to open the jaws wide enough for the pipe being clamped.
6. Place the clamp over the pipe and/or fitting to be clamped (fitting should be between the arms if used).

7. Turn clamping handles clockwise to tighten the clamp onto the pipes and ensure it is tight and does not allow for movement or sliding of the pipes.

Removal

To remove the clamp, turn the clamping handles anticlockwise until the jaws are wide enough to allow the clamp to be removed from the pipe.



Storage

IMPORTANT! When not in use always:

1. Store the tool in the carry case provided.
2. Ensure the tool is clean and dry before storage.

Routine Maintenance

1. Check for correct movement and operation and lubricate moving parts at regular intervals before using.
2. It is important to ensure all component parts are present and in serviceable condition.

04. Operation: Megaclamp Universal

Instructions for Use

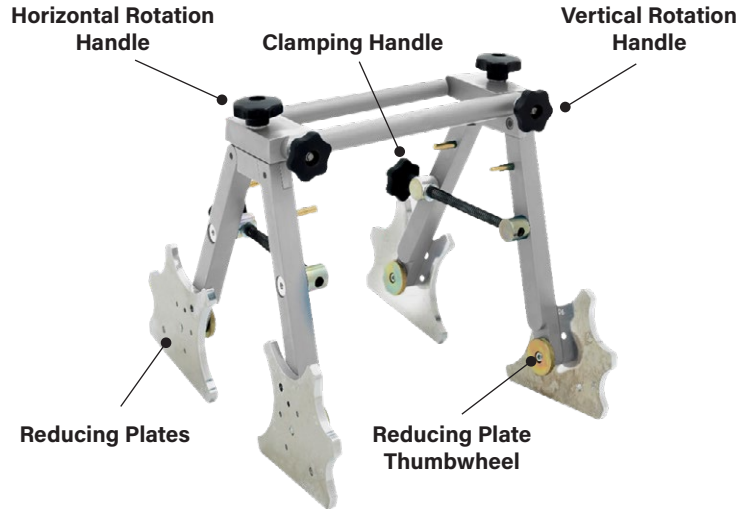

1. Check the pipe size and select the correct side of the reducing plates.
2. If a different size is required, turn the reducing plate thumbwheel anticlockwise fully. Pulling the plate away from the locating pin will allow the plate to rotate. Rotate the plate until the desired size is between the jaws. Note; if using a reducing coupler different sides of the plates can be used at either side of the clamp.
3. The reducing plate should be pushed onto the locating pin to prevent unwanted rotation. Then turn the reducing plate thumbwheel clockwise to lock in place.
4. Repeat steps 2 and 3 for the remaining legs of the tool.
5. Should an angle be required the angle between the arms can be rotated in 2 axes. For vertical rotation of either leg the vertical rotation handle should be loosened by turning anticlockwise, the desired angle selected, the handle should then be tightened by turning clockwise.

6. For horizontal rotation follow step 5 using the horizontal rotation handle.
7. Turn clamping Handles anticlockwise to open the jaws wide enough for the pipe being clamped.
8. Place the clamp over the pipe and/or fitting to be clamped (fitting should be between the arms if used).
9. Turn clamping handles clockwise to tighten the clamp onto the pipes and ensure it is tight and does not allow for movement or sliding of the pipes.

Removal

To remove the clamp, turn the clamping handles anticlockwise until the jaws are wide enough to allow the clamp to be removed from the pipe.



Storage

IMPORTANT! When not in use always:

1. Store the tool in the carry case provided.
2. Ensure the tool is clean and dry before storage.

Routine Maintenance

1. Check for correct movement and operation and lubricate moving parts at regular intervals before using.
2. It is important to ensure all component parts are present and in serviceable condition.

05. Specifications: Megaclamp Straight

Materials:	Mild Steel, Stainless Steel, Aluminium, Plastic
Finish:	Natural / Zinc plated (Steel)
Pipe Range:	Up to 200mm max
Dimensions:	330mm x 360mm x 360mm
Weight:	4.2kg
Min pipe Diameter:	63mm
Max pipe Diameter:	125mm
SDR:	All SDR Rating
Product Code:	53MB0101

This unit is design and manufactured to meet the requirements of National Grid Gas Industry Standards GIS/PL2-5 Part 5 Electrofusion and Ancillary Tooling.

Caldervale Technology Ltd has a policy of continuous improvement in product quality and design. Caldervale Technology Ltd therefore reserves the right to change the specification of its models at any time, without prior notice.

It is the responsibility of the operator to ensure that the PE pipe is suitable for this clamping system if in doubt contact the PE pipe manufacturer for confirmation.

06. Specifications: Megaclamp Universal

Materials:	Mild Steel, Stainless Steel, Aluminium, Plastic
Finish:	Natural / Zinc plated (Steel)
Pipe Range:	Up to 200mm max
Dimensions:	550mm x 250mm x 350mm
Weight:	6.35kg
Min pipe Diameter:	63mm
Max pipe Diameter:	125mm
SDR:	All SDR Rating
Product Code:	53MB0102

This unit is design and manufactured to meet the requirements of National Grid Gas Industry Standards GIS/PL2-5 Part 5 Electrofusion and Ancillary Tooling.

Caldervale Technology Ltd has a policy of continuous improvement in product quality and design. Caldervale Technology Ltd therefore reserves the right to change the specification of its models at any time, without prior notice.

It is the responsibility of the operator to ensure that the PE pipe is suitable for this clamping system if in doubt contact the PE pipe manufacturer for confirmation.

07. Parts Diagram

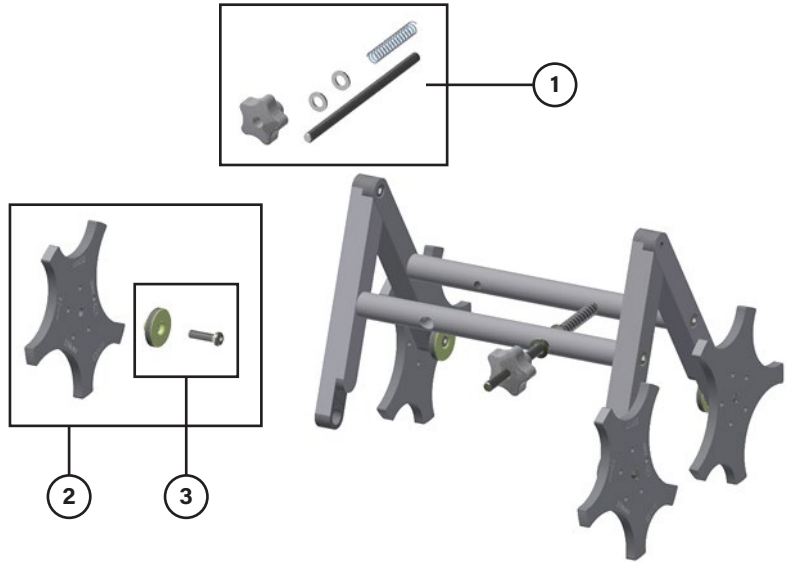

Note: Some spares listed can be applied to both the Megaclamp Straight and Megaclamp Universal.

Part	Product Code	Description
1	TBC	Clamping Handle Repair Kit Megaclamp Straight
1	TBC	Clamping Handle Repair Kit Megaclamp Universal
2	TBC	Reducing Plate Repair Kit
3	TBC	Reducing Plate Thumbwheel Repair Kit
5	01-15-066	Mains Clamp (200mm) Clamping Handle comes with Thread and Toggle

08. Warranty Information

1. Extent of Warranty

- a) Subject to clauses 2 and 3, Caldervale Technology Ltd warrants to the end-user customer that its products will be free from defects in materials and workmanship, for six months after the date of purchase by the end-user customer, subject to providing proof of purchase.
- b) If Caldervale Technology Ltd receives, during the warranty period, notice of a defect in product which is covered by this warranty; Caldervale Technology Ltd shall either repair or replace the product, at its option. Any replacement product may be either new or like-new, provided that it has functionality at least equal to that of the product being replaced.
- c) All warranty work will be carried out by Caldervale Technology Ltd unless otherwise agreed. On-site warranty and repair or replacement services are available from authorised Caldervale Technology Ltd service facilities world-wide.
- d) Customers shall prepay shipping charges for products returned to Caldervale Technology Ltd for warranty service, and Caldervale Technology Ltd will charge for return of the products back to the customer.
- e) This warranty statement gives the customer specific legal rights. The customer may also have other rights which vary from country to country in the world.

2. Pre-conditions for Warranty Application

Caldervale Technology Ltd's warranty covers only those defects which arise as a result of normal use of the product, and this warranty shall only apply in the following circumstances:

- a) All the instructions contained in the operating manual have been complied with; and
- b) None of the following apply:
 - i) Improper or inadequate maintenance;
 - ii) Physical abuse;
 - iii) Unauthorised modification, misuse or any use not in accordance with the operating manual and good industry practice;

- iv) Operation outside the products specifications;
- v) Improper site preparation or maintenance;
- vi) Faulty pipes.

3. Limitations of Warranty

- a) Caldervale Technology Ltd does not warrant the operation of any product to be uninterrupted or error free.
- b) Caldervale Technology Ltd makes no other warranty of any kind, whether express or implied, with respect to its products. Caldervale Technology Ltd specifically disclaims the implied warranties of satisfactory quality and fitness for a particular purpose.
- c) To the extent that this warranty statement is inconsistent with the law of the locality where the customer uses the product, this warranty statement shall be deemed modified by the minimum necessary to be consistent with such local law.
- d) To the extent allowed by local law, the remedies provided in this warranty statement are the customer's sole and exclusive remedies.
- e) This tool has been designed for the range of pipes available at the time of its design and development. Caldervale Technology Ltd can accept NO liability for the unit's ability or otherwise to work with new or different pipes that subsequently appear in the market place.

Please complete this information and keep it safely with your proof of purchase receipt. You will require it for any warranty claim.

Where purchased: _____

Date of purchase: _____

Name of purchaser: _____

Address of purchaser: _____

Type of tool: _____

Serial number: _____

09. Service and Repair

This product has no specific calibration period, however periodic safety inspections should be carried out by the operator as specified in this manual, if in any doubt please contact the manufacturer for further information.

INTERNATIONAL

Caldervale Technology Ltd

Bretfield Court, Dewsbury,
West Yorkshire WF12 9BG, UK

T. +44 (0)1924 469571

E. sales@caldertech.com

W. caldertech.com

AUSTRALIA / NZ

Caldertech Australia Pty Ltd

Unit 3/30 Juna Drive,
Malaga WA 6090, Australia

T. +61 (0)8 9209 1132

E. sales@caldertech.com.au

W. caldertech.com.au

10. Decommissioning and Disposal

These give the instructions for decommissioning and disposal of the equipment and confirm how it is to be taken out of service safely, in respect of the Essential Environmental, Health and Safety Requirements.

- If a Caldertech MegaClamp has reached the end of its useful working life and cannot be refurbished it must be sent to a licensed recycling facility for treatment. That will ensure the waste hierarchy requirements are met.
- End of life treatment is the responsibility of the Customer. This can also be achieved by returning the product back to the manufacturer if required.



Certificate of Conformity

This document certifies that the product detailed below fully conforms to the following standard without derogation.

GIS/PL2-5:2018 Electrofusion Ancillary Tools

Product: Megaclamp Tools

MARCH 2019



I. Smith
Managing Director



Caldervale Technology Ltd
Bretfield Court, Dewsbury, West Yorkshire WF12 9BG, UK
CRN 2769288 | ISO 9001:2015 Certified FM 30989



INTERNATIONAL

Caldervale Technology Ltd

Bretfield Court, Dewsbury,
West Yorkshire WF12 9BG, UK

T. +44 (0)1924 469571

E. sales@caldertech.com

W. caldertech.com

AUSTRALIA / NZ

Caldertech Australia Pty Ltd

Unit 3/30 Juna Drive,
Malaga WA 6090, Australia

T. +61 (0)8 9209 1132

E. sales@caldertech.com.au

W. caldertech.com.au



Caldertech
.com